

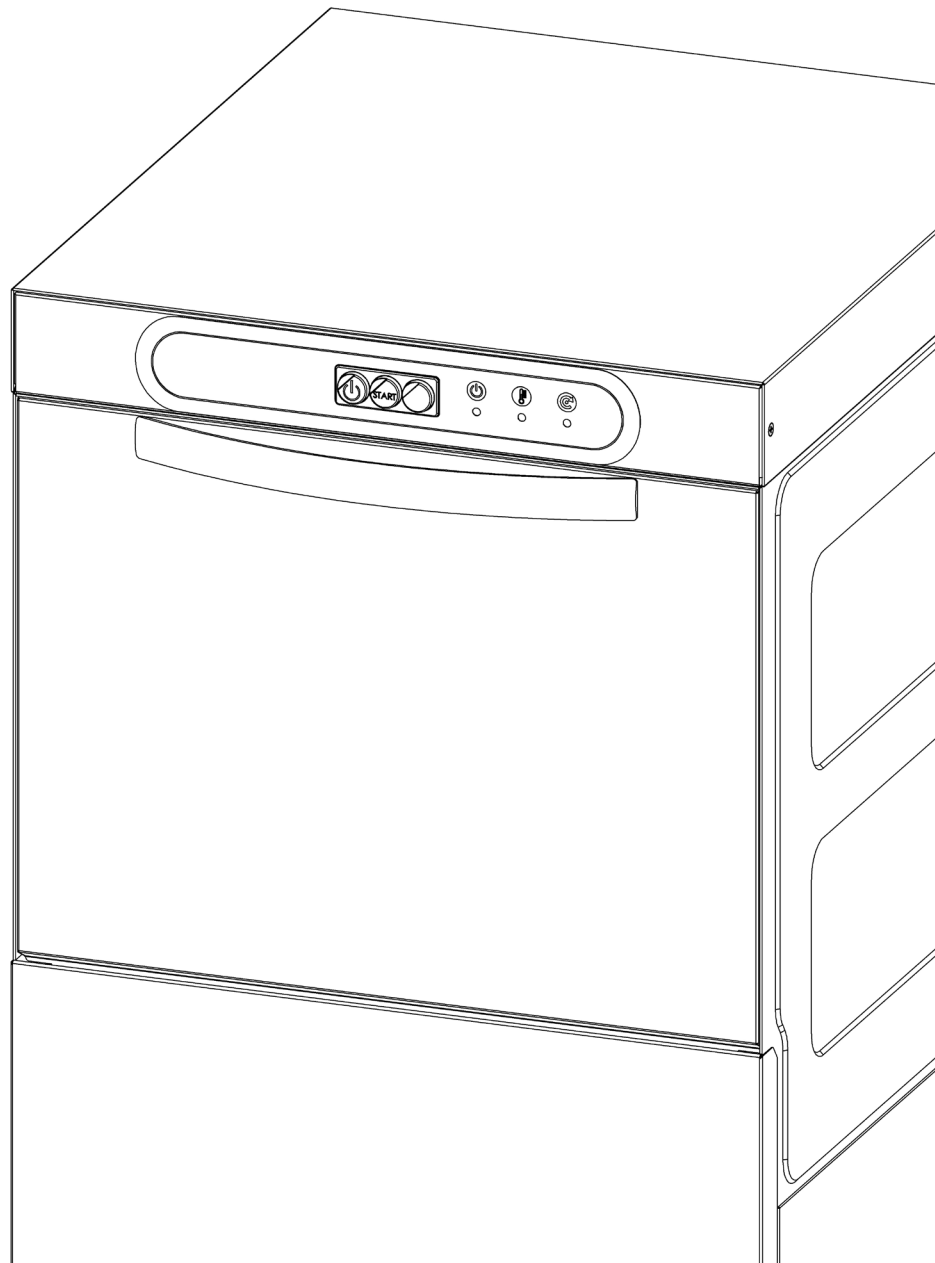

Instruction and Maintenance Manual

Electro-mechanical dishwasher







TRANSLATION FROM THE ORIGINAL LANGUAGE

SYMBOLS KEY	5
WARNINGS	6
PART ONE	8
1. Purpose of the information contained in PART ONE	8
2. Reference standards	8
3. Applicability	8
4. Transportation	8
5. Instructions for transportation, storage, unpacking and assembly	9
6. Dishwasher identification and marking	10
PART TWO	11
1. Purpose of the Manual	11
1.1. Who should read this manual	11
1.2. Use and preservation of this manual	11
1.3. Duration and validity of this manual	11
1.4. Request for a copy or a new manual	11
1.5. Update	11
1.6. Transfer of ownership	11
1.7. Customer's suggestions	11
1.8. Liability Limits	12
1.8.1. Use Limits	12
1.8.2. Regulations to be observed	12
1.8.3. Liability	12
2. Installation	13
2.1 Positioning and levelling	13
2.2 Electric connection	14
ELECTRICAL INSTALLATION OF A SINGLE-PHASE DISHWASHER	15
THREE-PHASE DISHWASHER ELECTRICAL INSTALLATION	16
2.3 Earthing	18
2.4 Water supply	18
2.5 Connection to the water drain	19
2.6 Model with drain pump	19
2.7 Detergents installation	20
3 How to use the dishwasher	20
3.1 Type of use	20
3.2 Use conditions	20
3.3 Dishwasher types	20
3.4 Use limits	21
3.5 Operator	21

4 Instructions for use of the electro-mechanical dishwasher	21
4.1 Check general operation	21
4.2 Safety devices	21
4.2.1 General safety devices	21
4.2.2 Alarm signals	21
4.2.3 Indicators and signalling on the electro-mechanical dishwasher	22
4.2.4 Interlock devices	22
4.2.5 Removable and adjustable safety guards	22
4.3 Safety measures	22
4.4 Unladen test	23
4.5 Washing operations	23
4.6 Electromechanical dishwasher operation	24
4.7 End of service	27
4.8 Thermostop	28
5 Instructions for disassembly	29
6 Maintenance	29
7 Residual hazards	32
8 Instructions for emergency situations	33
9 Troubleshooting	33
9.1 Electromechanical dishwasher alarms	36
10 Personnel training	37
11 Useful tips	37
12 Instructions for disposal	38
WARNING	38

SYMBOLS KEY

SYMBOL	DESCRIPTION
	ATTENTION - RISK OF INJURIES This symbol marks information and warnings which if not respected can jeopardise personal safety or damage the appliance.
	ELECTROCUTION HAZARD This symbol marks information and warnings which if not respected can jeopardise personal safety or damage the appliance.
	BURNING HAZARD This symbol marks information and warnings which if not respected can jeopardise personal safety or damage the appliance.
	DANGER OF FALLING This symbol marks information and warnings referring to situations when using the product, where lack of attention can jeopardise personal safety.
	READ ALL THE INSTRUCTIONS read and fully understand all the instructions contained in this manual. Keep the Manual in a place that is easily accessible to the dishwasher user in order to allow consultation with speed and convenience. Do not use the dishwasher if the manual cannot be consulted.

WARNINGS

Please read the following general warnings carefully.

- ▶ Dear customer we inform you that the product purchased is a dishwasher
- ▶ This appliance must only be used to wash food-type dirt from glasses, cups, dishes and similar products, the residues of which have previously been removed also by means of pre-soaking without detergents as explained in the "Instructions for Use" chapter of this manual. The dishwasher may only be used to wash plates and glasses commonly used in bars and restaurants. Any other kind of usage is strictly forbidden. The dishwasher was NOT designed to wash dishes or accessories made of plastic, to wash glass that can explode on contact with hot liquids or to wash bottles and material for infants, such as crockery or equivalent containers.
- ▶ Please make sure you have fully read and completely understood this manual before using the dishwasher.
- ▶ The manual must be kept within the user's reach so that it can be consulted easily and quickly. Should it be damaged, destroyed or lost, please ask your constructor for a new copy (see para. 1.4 - PART TWO)
- ▶ **Do not use the dishwasher if you cannot consult the manual.**
- ▶ Follow the Instruction and Maintenance Manual with the utmost care both for use and maintenance operations.

The dishwasher has been designed and manufactured in compliance with EMC Regulations EN55014-1:2006+A1:2009+A2:2011; EN55014-2:2015; EN61000-3-2:2014; EN61000-3-3:2013 Safety Electrical EN60335-2-58:2005 (incl. Corr.:2007)+A1:2008+A11:2010 used in conjunction with EN60335-1:2012; EN62233:2008 (incl. Corr.:2008).

- ▶ The maximum noise level of our dishwashers is 74.3dB and the KpA value = 2.5db
- ▶ The dishwasher must only be used by trained operators.
Untrained operators must be supervised by a manager or a colleague with sufficient experience in the use of dishwashers until it is considered they have acquired adequate experience to operate it independently.
- ▶ Children must be supervised to ensure they are not playing with the machine;
- ▶ This appliance is not intended to be used by persons (children included) with reduced physical, sensory or mental capabilities or with insufficient experience and knowledge, unless they have received assistance or instructions for use of the appliance from a person responsible for their safety.
- ▶ The use of the machine by operators who are not legally employed is forbidden.
- ▶ Always keep the dishwasher and the area around it clean, so that the operator and their equipment can transit quickly and safely. Do not pile up objects or other material that could prevent easy access to the door.
- ▶ In the event of danger, immediately remove the power supply to the dishwasher by pressing the power button or by disconnecting the appliance from the mains.
- ▶ The positioning, installation and commissioning of the dishwasher must be carried out by adequately qualified and certified personnel.

The dishwasher can operate in a temperature range of +10 to + 50°C.

- ▶ The electrical connection must be carried out in compliance with the current regulations of the country in which the machine is installed.
- ▶ Before connecting the machine, make sure that the voltage and frequency of the mains correspond to what is indicated on the data plate and that the machine is connected to an effective earthing system;
- ▶ At the back of the machine there is a clamp marked with the symbol  necessary for the equipotential connection between the various devices.
- ▶ The machine must be protected upstream against overloads and short-circuits by an omnipolar magnetothermic switch, with adequate breaking capacity, or by an underload disconnecter and fuses of the gL type of suitable capacity. A residual current circuit breaker coordinated with the resistance value of the user's earthing system must be installed immediately downstream of the circuit breaker switch of the sectioning switch/fuses against indirect contacts.
- ▶ The maximum supply water temperature is 55°C.
- ▶ The water supply pressure must respect the limits indicated in the technical data (200/350 kPa)
- ▶ After washing, switch off the dishwasher if it is no longer needed.
- ▶ Clean the filter every day.
- ▶ Clean the whole dishwasher at least once a week.

- ▶ Check the integrity of the power cord daily, especially if the point of connection to the mains is not near the dishwasher.
- ▶ The power cord supplied with the machine is of the H07RN-F type. If the cord is damaged, disconnect the dishwasher from the mains and immediately contact an authorised service centre to replace the cable.
- ▶ Position the cord appropriately, avoiding situations in which it could be damaged (avoid repeated trampling of the cord, passage of the cord under doors, etc.).
- ▶ Perform regular maintenance, as indicated in the Instruction and Maintenance Manual.
- ▶ Maintenance activities must only be carried out when the dishwasher is switched off and disconnected from the power supply and with the tank empty.
- ▶ Before performing maintenance, wait for elapse of the resistances cooling time (at least 5 minutes). Do not open the dishwasher door/lid if the cycle is in progress. As an interlocking device, a microswitch is used, located on the dishwasher door that stops the water jet in the dishwasher, but does not remove the electrical voltage from the machine.
- ▶ Ordinary maintenance activities must be carried out safely using protective gloves and goggles.
- ▶ Never use the appliance with wet hands or feet
- ▶ Never immerse bare hands into the tank water
- ▶ Extraordinary maintenance, repair and replacement of components must be performed by suitably qualified and certified personnel. Use only original spare parts. The manufacturer declines all responsibility for accidents to persons or property arising from the use of incompatible and/or non-original spare parts
- ▶ The degree of protection of the machine is IPX1 and therefore must not be washed with high pressure water jets or steam nozzles.
- ▶ It is forbidden to use the dishwasher with detergents or rinse aid products of a type different from the recommended one (such as dishwashing powder, washing powder and rinse aid for domestic dishwashers), or to use descalers that are corrosive, acidic and in general unsuitable cleaning liquids or powders. Do not add bleach to the washing tank.
- ▶ Use only liquid industrial detergent and rinse aid products such as those supplied by us or with an equivalent composition suitable for dosing using the dosing pumps already installed inside the dishwasher.
- ▶ Never use scouring pads or wire brushes to clean the dishwasher
- ▶ Do not use the appliance upside down. Do not climb onto the door or above the dishwasher as this could result in the risk of it tipping over.
- ▶ The dishwashers with square 350x350, 400x400 and with round basket Ø350 and Ø400 are not suitable for dishwashing.

N.B. The manufacturer declines all responsibility for accidents to persons or property deriving from non-observance of the afore-mentioned regulations or from improper use, maintenance or repair.

ATTENTION!



ELECTROCUTION HAZARD

PART ONE

1. Purpose of the information contained in PART ONE

The purpose of the information contained in PART ONE is to inform the Customer about the necessary data for correct identification of the dishwasher.

2. Reference standards

The dishwasher has been designed and manufactured in compliance with EMC Regulations EN55014-1:2006+A1:2009+A2:2011; EN55014-2:2015; EN61000-3-2:2014; EN61000-3-3:2013 Safety Electrical EN60335-2-58:2005 (incl. Corr.:2007)+A1:2008+A11:2010 used in conjunction with EN60335-1:2012; EN62233:2008 (incl. Corr.:2008).

This dishwasher also complies with the Safety and Work Hazard Prevention Regulations (applicable to dishwashers) in force at the date of manufacture.

The dishwasher's connection with a suitable residual current operated circuit-breaker according to IEC 947 standard (type 1 coordination) is highly recommended; the maximum noise level of our dishwashers is 74.3dB and the value $K_{pa}=2.5db$

3. Applicability

The instructions found in this manual are only suited for the type of dishwasher specified.

4. Transportation

The machine is packed in a heavy cardboard crate when transported (fig. 1).

The dishwasher weight may vary between 50 and 170 kg if packed on a pallet, according to the model.

ATTENTION!



INJURY HAZARD

THE USE OF EQUIPMENT AND THE OPERATIONS NOT SUITED TO LOADING, UNLOADING AND HANDLING OF THE DISHWASHER MAY DAMAGE BOTH THE PERSONNEL IN CHARGE OF SUCH OPERATIONS AND THE MACHINE ITSELF. THE MANUFACTURER RECOMMENDS COMPLYING WITH THE STANDARDS ON LOADING, UNLOADING AND HANDLING IN FORCE IN THE COUNTRY WHERE THE DISHWASHER IS USED.

THE MANUFACTURER DECLINES EVERY RESPONSIBILITY FOR DAMAGE TO THINGS OR PERSONS CAUSED BY IMPROPER USE OF THE EQUIPMENT OR BY PROCEDURES NOT SUITED TO AND/OR NOT SUITABLE FOR LOADING, UNLOADING AND HANDLING OF THE DISHWASHER.

Fig. 1

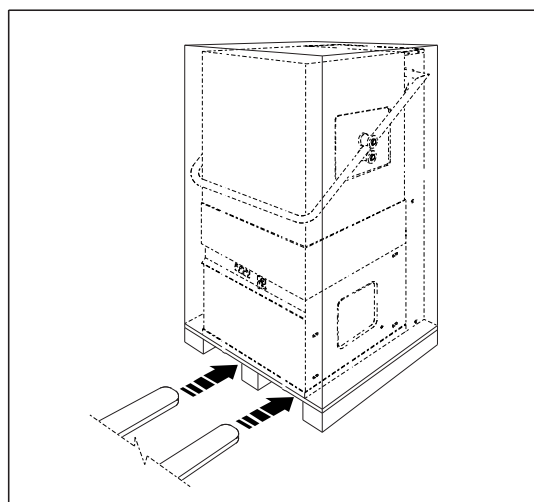

Once the dishwasher has arrived at its destination, check the transport documents and the number of packs. Should you find any discrepancy between the documents and the items delivered, contact your Dealer immediately.

Carefully check the condition of the packaging: if it proves to be faulty or broken or with signs of incorrect handling, immediately inform the Supplier.

Please do not throw the packaging accessories away as they may be needed to ship the machine back to your Dealer.

5. Instructions for transportation, storage, unpacking and assembly

5.1 Transportation

All dishwashers are packed on pallets and cardboard crimped to the pallet. The dishwasher must only be moved by forklift truck or transpallet, taking care to keep the dishwasher balanced, avoiding sudden movements. Do not lay the dishwasher down, respect the vertical positioning as shown by the arrow printed on the cardboard.

5.2 Storage

If the dishwasher is to be stored, ensure that the storage environment temperature is between +5 and +45°C, with humidity below 80%. The dishwasher must be packed in its original packaging (pallet and cardboard) and in a vertical position as shown by the arrow printed on the cardboard. The pallet can be placed on the ground on a dry and dust-free floor, or on a pallet holder, ensuring that the maximum load indications shown on the pallet holder are respected, and secured to prevent falls due to impact or vibration. It is not permitted to stack other material on top of the dishwasher cardboard.

Periodically check the correct position of the packaged dishwashers and the integrity of the packaging.

5.3 unpacking and assembly

ATTENTION!



INJURY HAZARD

PLEASE PAY SPECIAL ATTENTION DURING UNPACKING AND ASSEMBLING OPERATIONS BECAUSE OF THE INSTABILITY OF THE DISHWASHER.

The unpacking/assembling instructions are only valid if the machine is installed by the Customer themselves.

1. Open the cardboard packaging carefully (fig. 2).

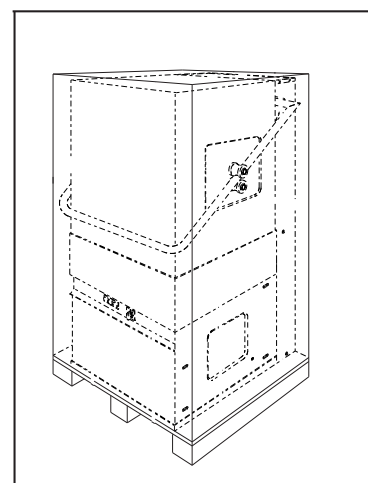

Fig. 2

2. Loosen the two A screws that fasten the dishwasher to the transportation pallet (fig. 3)

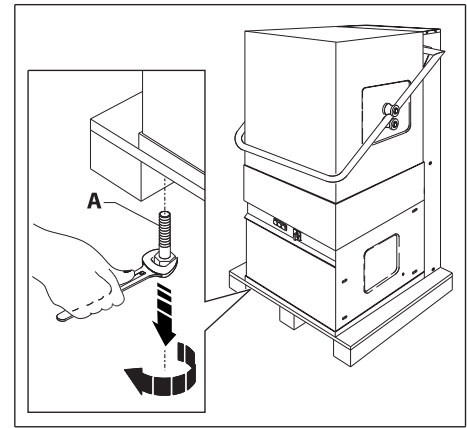

Fig. 3

3. Move the machine on the pallet until freeing of two of the four holes for insertion of the support feet (fig. 4).
Take one of the supplied feet and tighten the screw in one of the two seats vacated (fig. 4).
Proceed with installation of the second foot following the same procedure (fig. 4).

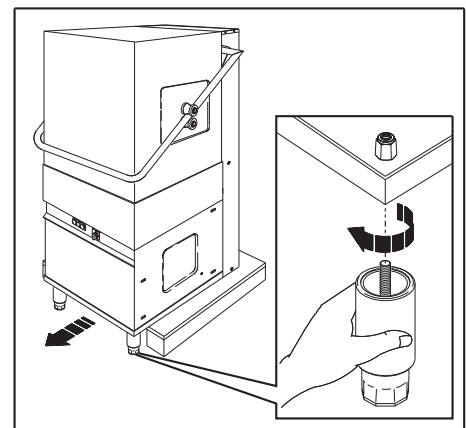

Fig. 4

4. Move the machine until it is positioned on one side on the mounted feet and the other on the pallet in order to free the other two holes, then proceed with assembly with the same procedure.

6. Dishwasher identification and marking

The dishwasher bears the following identification marks:

- Company name
- CE marking
- Indication of model and type
- Year of manufacture
- Test certificate

This information is shown on the plate situated on the dishwasher (fig. 5) and can also be found on the declaration of conformity enclosed herewith.

Fig. 5

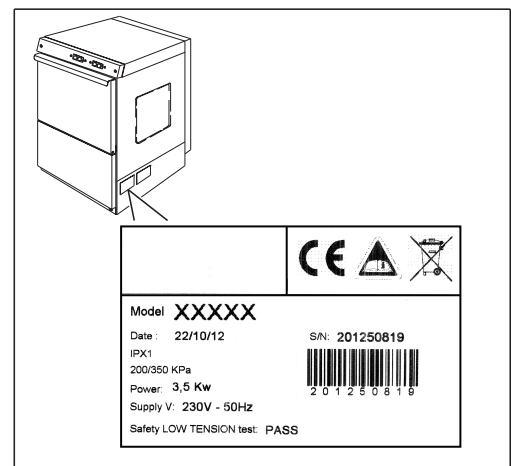

1. Purpose of the Manual

The purpose of this Instruction and Maintenance Manual is to provide a description of the safety measures necessary for the use which must be observed when using the dishwasher.

This Instruction and Maintenance Manual is to be considered an integral part of the dishwasher.

The term User comprises not only the purchaser of the dishwasher, but also the personnel involved in the operating, maintenance, checking and handling operations.

The information contained in this manual concerns installation, putting into service and maintenance operations.

1.1. Who should read this manual

This manual is intended for the dishwasher operator and maintenance technician.

1.2. Use and preservation of this manual

The purpose of this manual is to provide all the information needed to use and maintain the dishwasher properly, according to the safety standards established by the Machine Directives and the Unified Standards. For this reason, even if operation of the dishwasher is very simple, the manual must be kept intact and be readily available if required: it must remain close to the place of use, and be clean, legible and intact.

1.3. Duration and validity of this manual

This manual is to be considered valid for the entire life of the dishwasher.

It has been drawn up according to the current state-of-the-art technology existing at the time of construction of the dishwasher.

The manual therefore specifically refers to the dishwasher it was provided with, and is also to be considered valid in the event of future updates.

1.4. Request for a copy or a new manual

Should your copy of this Manual be lost or damaged, please ask your Manufacturer for a new one. Copies of the Instruction and Maintenance Manual can be requested by stating the serial number, registration number and year of manufacture of the dishwasher (fig. 5).

Copies are only available for a fee.

1.5. Update

The Manufacturer reserves the right to modify the dishwasher whenever necessary and/or to update previous manuals without giving prior notice, except in special cases.

The manual will be updated by the Manufacturer in the following cases:

- if the dishwasher is returned to the Manufacturer for modifications or improvements
- if the manual contains errors or omissions that may prejudice suitable use of the dishwasher in conditions of total safety.

In such cases, the original Manual supplied to the Customer must be returned to the Manufacturer who will provide a new updated copy.

1.6. Transfer of ownership

In case of sale or transfer of ownership of the dishwasher, the customer is required to give notice to the manufacturer, specifying the address of the new owner and the date of validity of the sale contract so that the manufacturer may inform the new owner of the limits of their liability.

1.7 Customer's suggestions

Customers are invited to communicate any suggestions or proposals they consider helpful to improve the use, legibility or preservation of this manual, in the spirit and terms of our Standards.

To communicate your suggestions, please contact the Manufacturer of this dishwasher.

1.8. Liability Limits

N.B. The manufacturer declines all responsibility for accidents to persons or property deriving from non-observance of the regulations mentioned in this manual or from improper use, maintenance or repair.

1.8.1. Use Limits

This appliance must only be used for the function for which it was designed, that is to wash glasses, cups and similar items which do not exceed the maximum height of the door opening, together with the basket that contains them, as specified for the different models.

The limits of use are determined by the space available and the overall dimensions of the baskets, as well as that of the dishes that may be washed.

The dishwasher may only be used to wash plates and glasses commonly used in bars and restaurants. The dishwasher was NOT designed to:

Wash plates, glasses or other accessories made of plastic

Wash glass items that could explode when in contact with boiling hot liquids

Wash baby feeding-bottles or other plates and food containers for babies.

Dishwashers with square 350x350, 400x400 and round basket Ø350 and Ø400 are not suitable for dishwashing.

Dishwashers with a 500x600 basket are not suitable for washing glasses.

1.8.2. Regulations to be observed

The regulations to be observed refer in particular to:

- ▶ *safety of the operator*
- ▶ *safety of the dishwasher*

The Manufacturer will accept no responsibility whatsoever if the dishwasher is used in such a way as to be in conflict with or that violates the safety regulations in force in the country of use, even if they enter into force during or after purchase.

1.8.3. Liability

The Manufacturer will accept no responsibility whatsoever for damage or injury to things or persons in any of the following situations:

- *Misuse of the dishwasher*

The term misuse refers to use of the dishwasher with dishes and items other than those recommended in the paragraph on the Use Limits (para 1.8.1 - PART TWO), which could result in damage or soiling of rotating parts and the splintering and/or explosion of the dishes.

Misuse is also to be considered the use of detergents or rinse aid products other than those recommended (such as dishwashing powder, laundry detergents specific for household dishwashers) or corrosive decalcifying products, acids and other unsuitable liquid or powdery cleaning products.

- *Use of the dishwasher by untrained personnel*

The dishwasher must only be handled by trained personnel. Untrained personnel using the machine should be supervised by a person in charge of the machine, until a certain degree of skill and safety has been achieved in correct use of the dishwasher.

- *Use not in compliance with national safety standards*

The use of the machine by operators who are not legally employed is forbidden.

- *Incorrect installation*

The dishwasher must be properly installed, both mechanically and electrically, and positioned in a suitable place that does not create difficulties for operators during its use.

This manual provides instructions referring to proper installation, when this is carried out by the Customer.

- *Faulty power supply*

A faulty mains power supply can cause damage to the internal motor pump and to the electrical parts of the dishwasher.

The Manufacturer accepts no responsibility for any damage caused by use of the machine with power supply voltages not in accordance with the relative Standards, namely:

- lower voltage limit: -10% of nominal voltage rating
- upper voltage limit: 250 Vac for 220 V single-phase nominal voltage rating and 440 V for three-phase nominal voltage rating 380 V.

- Failure to carry out regular, prescribed maintenance (see chap.6 – PART TWO)

Failure to carry out regular, ordinary maintenance is likely to cause damage or malfunction.

- Unauthorised modifications or tampering

The dishwasher cannot be modified or tampered with in any part whatsoever.

- Use of non-original or unsuitable spare parts for the specific model

We recommend contacting the authorised sales office when purchasing spare parts and, in any case, using spare parts only recommended or supplied by the Manufacturer.

- Total or partial non-observance of the instructions for use

ATTENTION!



SHOCK HAZARD

THIS MANUAL MUST BE READ CAREFULLY AND UNDERSTOOD BEFORE INSTALLING AND USING THE DISHWASHER.

Total or partial ignoring of the instructions for use of the dishwasher may expose personnel to safety hazards and cause damage to the machine.

- Natural events

In the case of exceptional events such as earthquakes, flooding, etc., the Manufacturer does not assume any responsibility for damage to things or persons due to the use of the dishwasher in the afore-mentioned conditions or even for total or partial reconditioning of the same.

2. Installation

ATTENTION!



SHOCK HAZARD

Installation operations are to be carried out by qualified personnel in compliance with the following instructions.

2.1 Positioning and levelling

The Manufacturer delivers the dishwasher already assembled and complete with all the accessories necessary to be used properly.

If possible, place the dishwasher close to the electric and water mains connections. The machine must be levelled on a flat surface by turning its 4 adjustable feet (fig. 6).

If the machine is recessed in undercounter installations, its side and back panels may be joined to adjacent furniture or walls. The load and drain pipes may be left or right oriented, but once the machine is positioned, the pipes and the electric cable must not be bent or compressed.

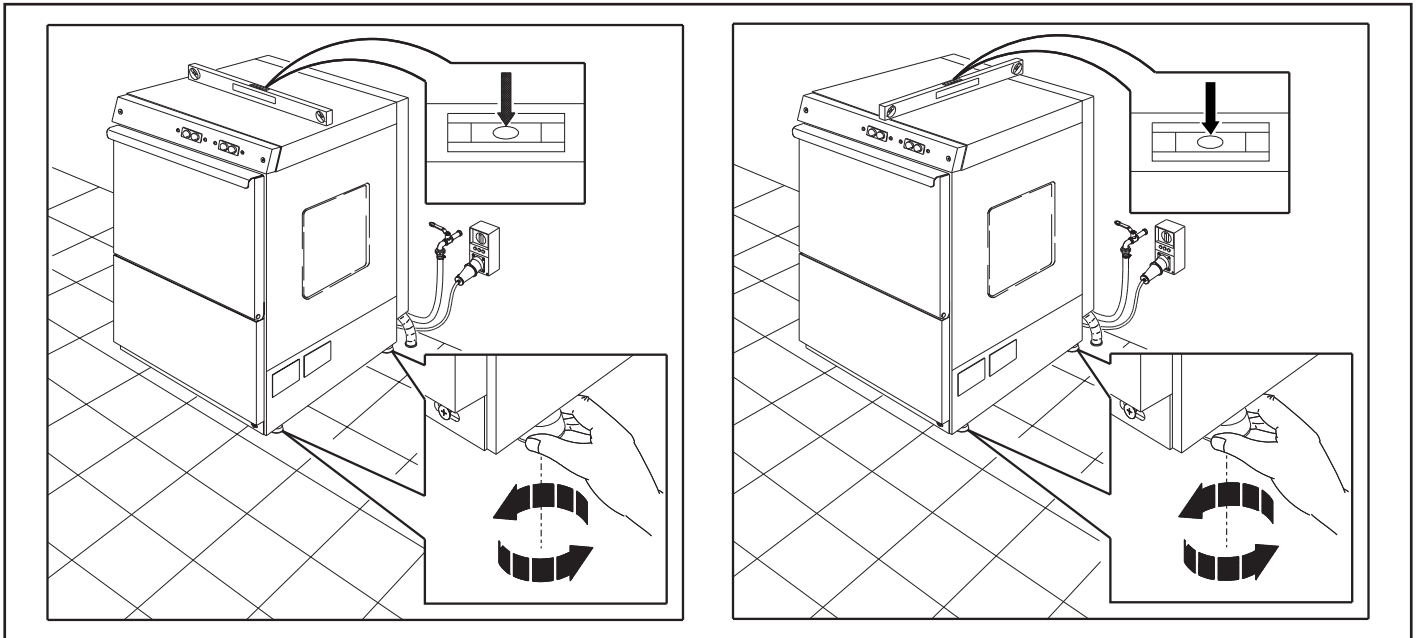

Fig. 6

2.2 Electric connection



ATTENTION!

The electrical connection must be carried out in compliance with the laws in force in the country in which the machine is installed.

Before connecting the machine, make sure that the voltage and the frequency of the electrical supply system correspond to that indicated on the plate and that the machine is connected to an efficient earthing system;

On the back of the machine there is a clamp marked with the  symbol, necessary for the equipotential connection between the different appliances.

The machine must be protected upstream against overcharges and short-circuits by an omnipolar thermal magnetic switch, with sufficient power of interruption, or by a load switch and gL-type fuses with adequate rate of flow.

A residual current circuit breaker coordinated with the resistance value of the user's earthing system against indirect contacts must be installed immediately downstream of the magnetothermic switch or of the circuit breaker/fuses.

The power cable supplied with the machine is H07RN-F-type.

ELECTRICAL INSTALLATION OF A SINGLE-PHASE DISHWASHER

Single-phase dishwasher with Schuko 230V+T plug

If the dishwasher is fitted with a plug, insert it into the wall socket. Connect the device to the equipotential system via the appropriate terminal on the back of the dishwasher.

Single-phase dishwasher without 230V+T plug

If the dishwasher does not have an electrical plug, perform connection as follows:

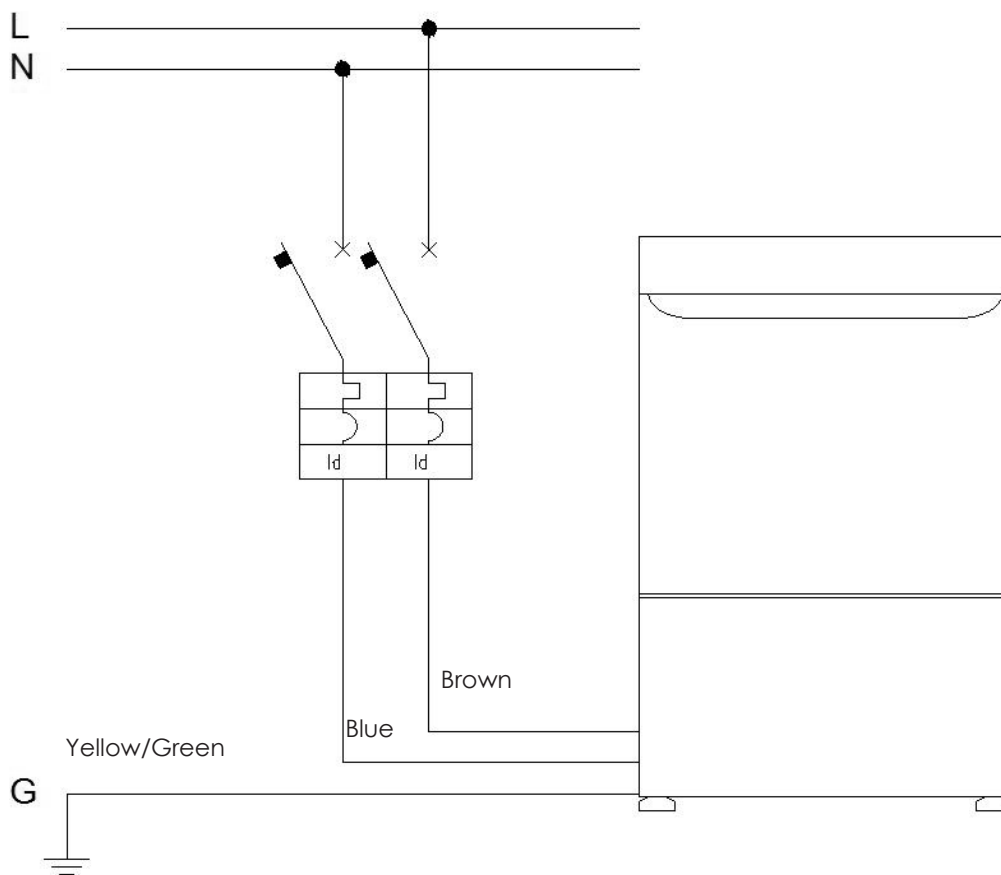

Brown wire: line

Blue wire: neutral

Yellow/green wire: earthing system

Connect the device to the equipotential system via the appropriate terminal on the back of the dishwasher

THREE-PHASE DISHWASHER ELECTRICAL INSTALLATION

400V3N+T three-phase dishwasher

The 400V three-phase dishwashers are always 5-pole and therefore fitted with a neutral conductor. Perform connection as follows:

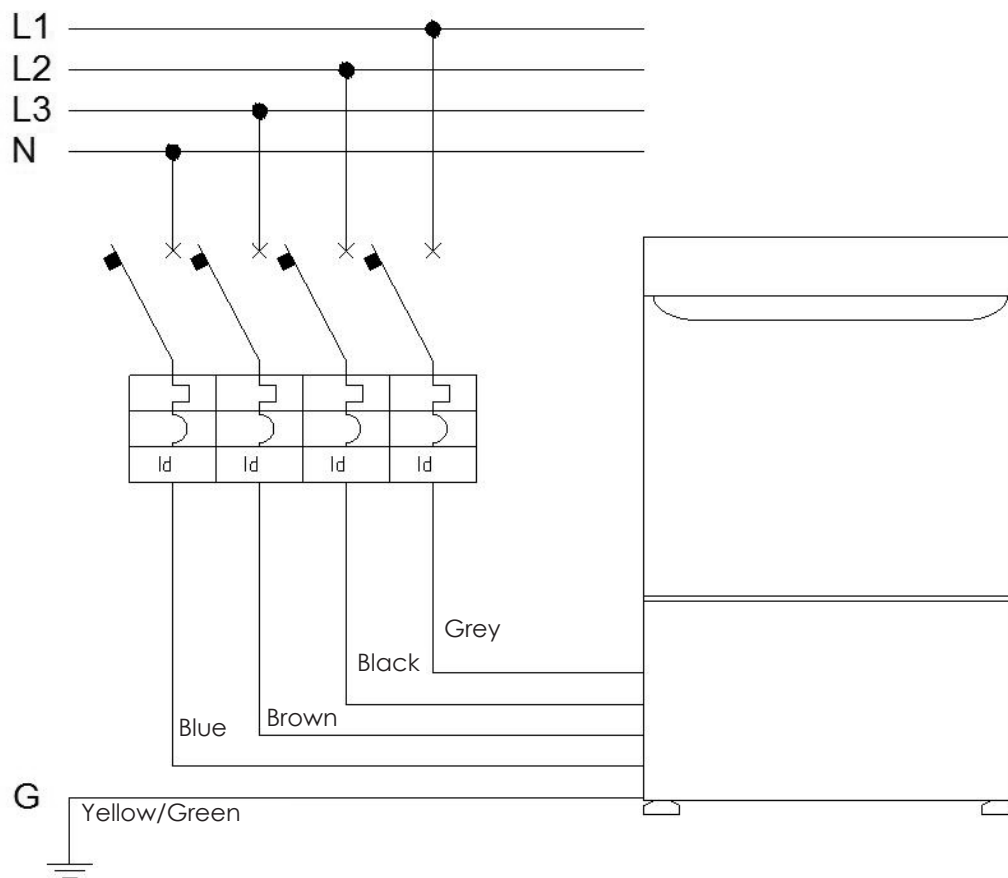

Brown wire: line 1

Black wire: line 2

Grey wire: line 3

Blue wire: neutral

Yellow/green wire: earthing system

If the dishwasher is provided with a three-phase motor, check for correct rotation of the pump following the instructions supplied with the dishwasher.

If the pump should rotate in the direction opposite to the arrow on the pump cover, invert L1 and L2. Connect the device to the equipotential system via the appropriate terminal on the back of the dishwasher.

230V3+T three-phase dishwasher (optional upon request)

230V three-phase 4-pole dishwashers are only provided upon express request when ordering. Subsequent transformation of the dishwasher may require the replacement of certain components. Perform connection as follows:

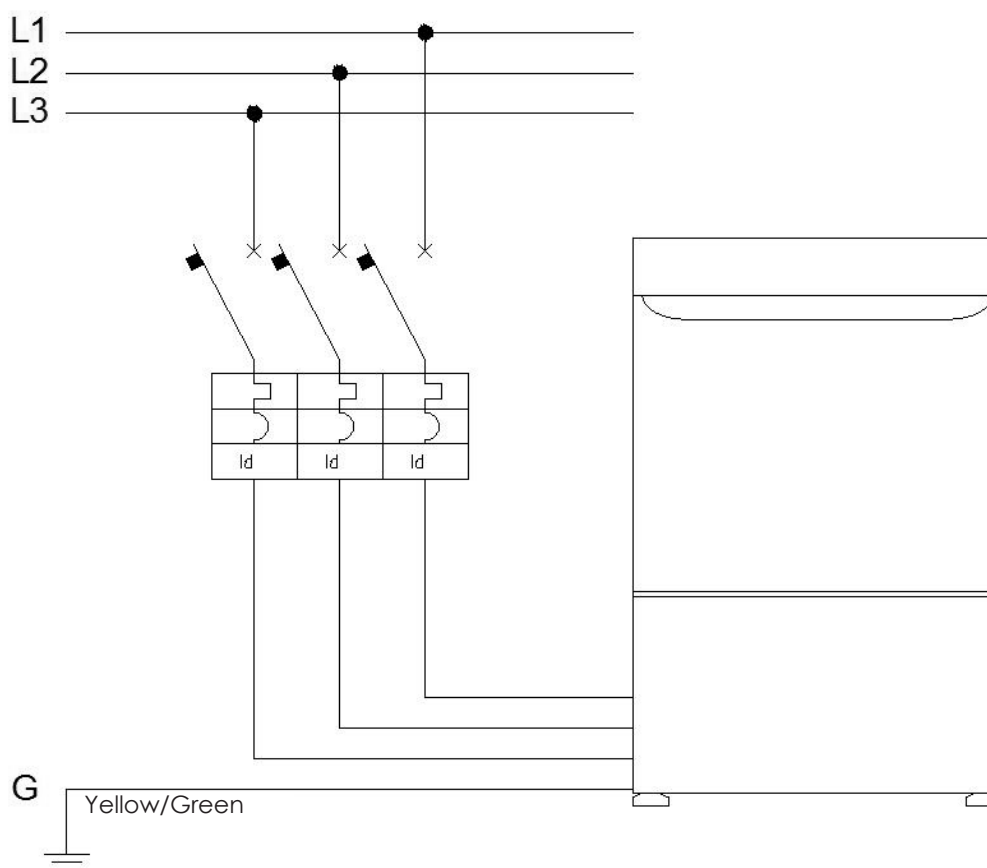

Brown wire: line 1

Black wire: line 2

Grey wire: line 3

Yellow/green wire: earthing system

If the dishwasher is provided with a three-phase motor, check for correct rotation of the pump following the instructions supplied with the dishwasher.

If the pump should rotate in the direction opposite to the arrow on the pump cover, invert L1 and L2. Connect the device to the equipotential system via the appropriate terminal on the back of the dishwasher.

Dishwasher without power cord

If the dishwasher is supplied without an electric cable, follow the attached instructions to connect it to the mains.

Connect the device to the equipotential system via the appropriate terminal on the back of the dishwasher.

2.3 Earthing

The dishwasher must be connected to the earthing system of the building or to another tested and approved system in compliance with the safety regulations.



ATTENTION!

It must however be understood that an efficient earthing system is not enough on its own to ensure safe conditions. It will therefore be necessary to install suitable safety devices capable of interrupting the mains power supply with intervention times in compliance with the IEC 64-8 Regulations or with the other equivalent European Standard referring to electrical systems in public buildings.

2.4 Water supply

Connect the load pipe supplied with the dishwasher to a $\frac{3}{4}$ " water intake, using it to replace any existing pipes.

The highest water supply temperature is 55°C.

The water supply pressure must respect the limits indicated in the technical data (200/350kPa).

Further indications:

- *It is advisable to use the pressure regulators if hydraulic supply takes place through autoclave at a pressure greater than that of normal operation of the water mains.*
- *If the water pressure available is less than 1.5 bar, to ensure rinsing it is necessary to install an external pump to increase pressure.*
- *If the water has a hardness above 14°f, a water softener should be used to prevent external lime deposits and unsatisfactory washing results.*
- *If water hardness is higher than 14°f, limestone forms.
If water hardness is lower than 8°f, the dishes will not be rinsed properly.*

The connection to the water supply is to be carried out by means of a normal screw-on attachment to a water valve fitted with a handle or hand wheel (fig. 8).

It is advisable to place a suitable gasket in the connection between the supply hose and the tap (fig. 8).

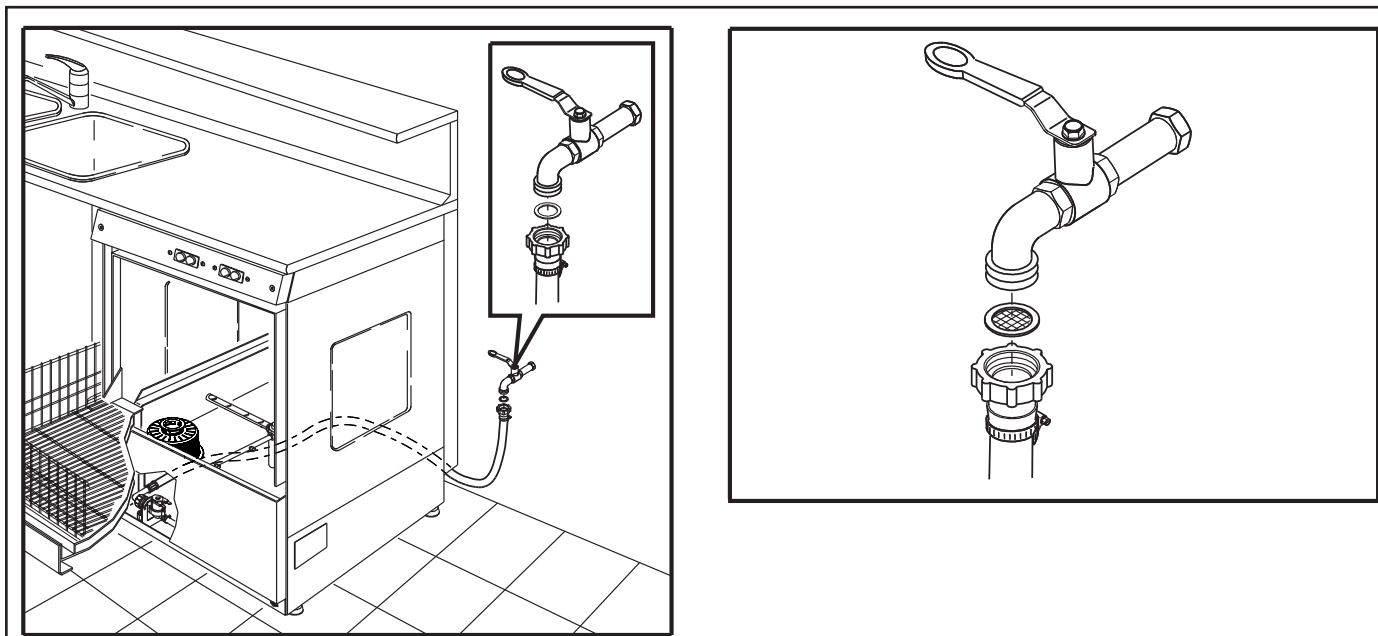

Fig. 8

2.5 Connection to the water drain

On the back of the machine there is an elbow connector which can be easily orientated towards the nearest drain well. (fig.9)

Whenever water drain cannot be by gravity, the model with a built-in drain pump must be specifically requested (fig.10): see in this regard para. 2.6 - PART 2.

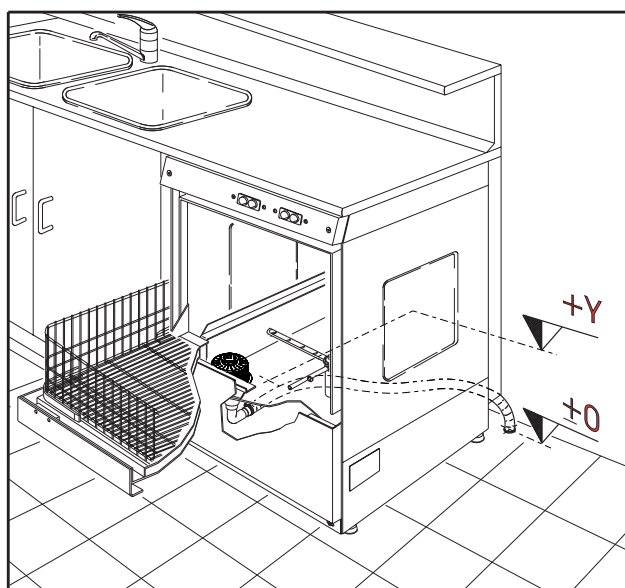

Fig. 9

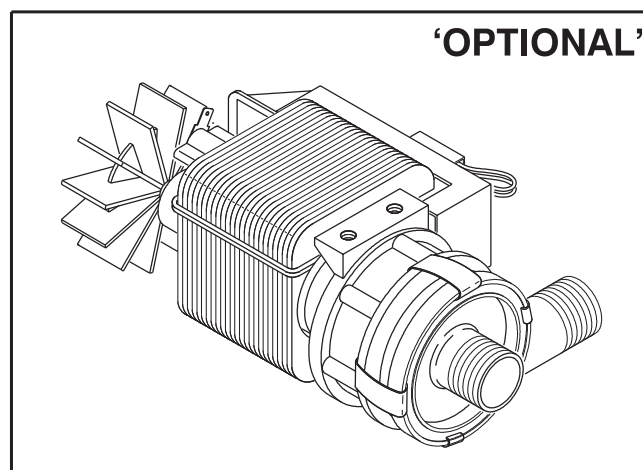

Fig.10

2.6 Model with drain pump

The end of a drain hose can be hooked-up to the edge of a sink, or connected to an outlet in the wall; this outlet must be provided with an air breather or have a diameter larger than that of the drain hose to allow the passage of air.

If an extension is required, it must not exceed 2 m in length.

Avoid exceeding the difference of 40 cm between the point of connection of the drain hose and the base of the dishwasher.

Make sure that the drainage pipe is always positioned on a slope and that it does not create pockets, siphon curves.



ATTENTION!

In the case of attaching to the edge of a sink, place the end of the exhaust pipe so that the drain water can not reach outlets or electrical equipment.

2.7 Detergents installation

The dishwasher is equipped with a blue tube for drawing of the rinse aid and a yellow tube for drawing of the detergent. Before inserting the tubes into their respective tanks, it is advisable to apply the weight and the filter supplied with the dishwasher to the end of these tubes (fig.A). The ceramic weight ensures drawing of the product from the bottom of the tank.

Important: never place the tubes into the tanks without having installed the filter; any crystallised parts of the product will seriously damage the dispensers.

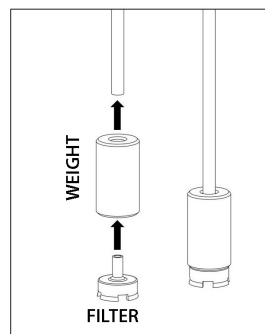

Fig.A

It is advisable to keep the detergent and rinse aid tanks in sight in order to continuously verify the presence of the product. Replace the tanks as soon as the product runs out.

3 How to use the dishwasher

3.1 Type of use

The dishwasher has been designed for washing dishes commonly used in bars and restaurants.

3.2 Use conditions

The dishwasher may be used under any condition, providing that the operating temperature range is between +10 and +50°C.

It must only be used with an operator present.

In any case, avoid using the dishwasher in open spaces, such as in uncovered areas, improvised sheds, or other temporary installations.

3.3 Dishwasher types

Items that can be washed:

- *for the glass-washer models: glasses, cups, coffee cups, stemware, saucers and fruit dishes, in compliance with what is indicated in the paragraph on Use Limits (para. 1.8.1 – PART TWO).*

- *for all the other models: all types of dishes, crockery and glasses within the limits determined by the size of the baskets, in compliance with the standards stated in the paragraph on Use Limits (para. 1.8.1 – PART TWO).*

3.4 Use limits

The dishwasher must be used for washing dishes stacked flat in the basket inside the machine, up to its full carrying capacity, with no overlapping (fig. 11).

Moreover, make sure that the dishes do not prevent the rotors from turning.

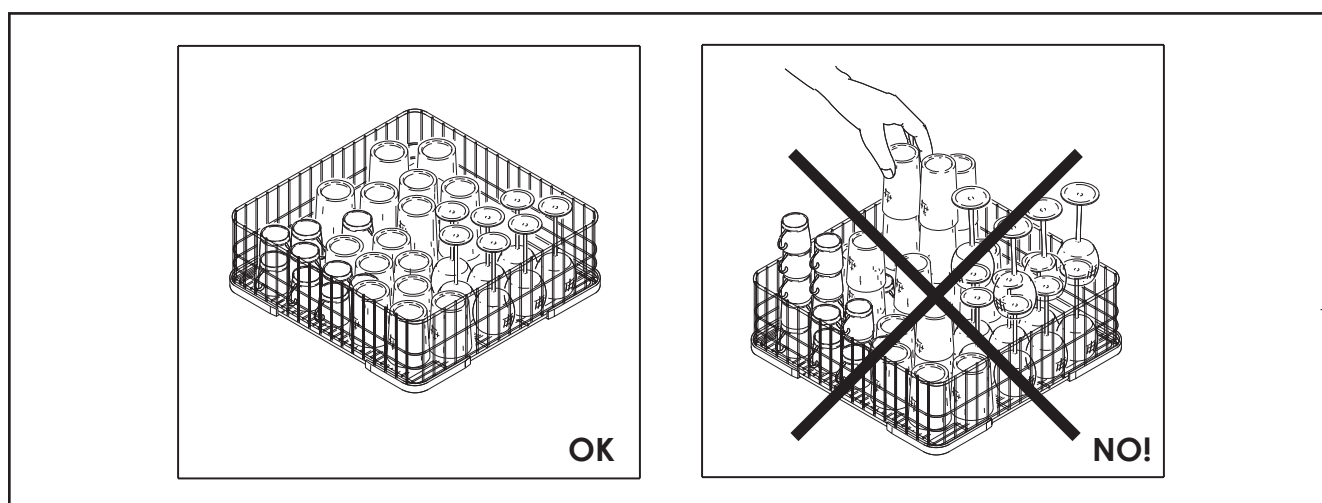

Fig. 11

3.5 Operator

The operator should have sufficient experience in the use of equipment commonly supplied to public businesses to prevent incorrect handling.

In any case, the simple commands and ease of operation when using the dishwasher facilitate acquiring of the necessary experience in a very short space of time.

The operator must always be aware of the risks (i.e. shock and burn hazards) due to use of any dishwasher.

The operator must be trained with special attention in the following cases:

- temporary employees, with little or no experience;
- personnel with little or no service practice;
- personnel with local language comprehension difficulties;
- physically disabled personnel with limited movement capabilities.

4 Instructions for use of the electro-mechanical dishwasher

This appliance must only be used by trained personnel and employed solely for the washing of glasses, saucers, cups and similar item, in compliance with the Use Limits described in par. 1.8.1 – PART TWO).

4.1 Check general operation

Before starting up normal operation, the User should check the functional characteristics of the installation by a visible inspection of connections to the dishwasher.

Regular inspection is also recommended regarding the conditions of connection of hoses and electric power supply cables (see chap. 2 – PART TWO).

4.2 Safety devices

4.2.1 General safety devices

The dishwasher is enclosed inside metal cabinets that can only be opened using appropriate tools.

4.2.2 Alarm signals

No alert signals are installed.

4.2.3 Indicators and signalling on the electro-mechanical dishwasher

RED POWER-ON LIGHT

The power supply is ON



CYCLE INSERTED LIGHT

The washing cycle is running



TANK TEMPERATURE LIGHT OK

Temperature water tank = 60°C



The lights can flash in different ways to indicate possible **error messages**. For further information on error messages, refer to paragraph 9.1 (Warnings and alarms dishwasher with digital display).

4.2.4 Interlock devices

As an interlocking device, a microswitch is used, fitted on the dishwasher door and positioned in such a way that it cannot be tampered with.

This micro switch stops the water intake in the event that the door is opened, without switching off the power supply on the machine. If the door is opened during heating of the tank, heating is interrupted

4.2.5 Removable and adjustable safety guards

No adjustable or removable guards are provided, as they are not necessary.

4.3 Safety measures

Several basic rules must be complied with when using the dishwasher:

- *The dishwasher must never be removed from its original position when working*
- *Make sure the water supply tap is open before turning the appliance on*
- *Never clean with corrosive products acids, steel wool or steel brushes*
- *Never wash the appliance with direct or high-pressure jets of water*
- *At the end of daily use, switch off the dishwasher*
- *Inspect the general situation of the machine before use, with particular attention to the electric power supply connections and the operation controls*
- *The dishwasher must be clean and possibly free from residues from previous wash cycles and in a good working condition. All the auxiliary accessories must be installed correctly and be efficient*
- *if the dishwasher, for any reason, must remain unused, it is advisable to display a sign with the wording "Out of Service". If necessary, disconnect the dishwasher from the mains*
- *In the event that a spoon or other small object falls inside the tank, the tank will need to be emptied:*
 1. *turn off the dishwasher using the POWER SWITCH (see para. 4.6) and disconnect it from the mains*
 2. *remove the overflow pipe (fig. 16)*
 3. *if supplied, operate the drain pump by holding down the DRAIN PUMP BUTTON (see para. 4.6)*

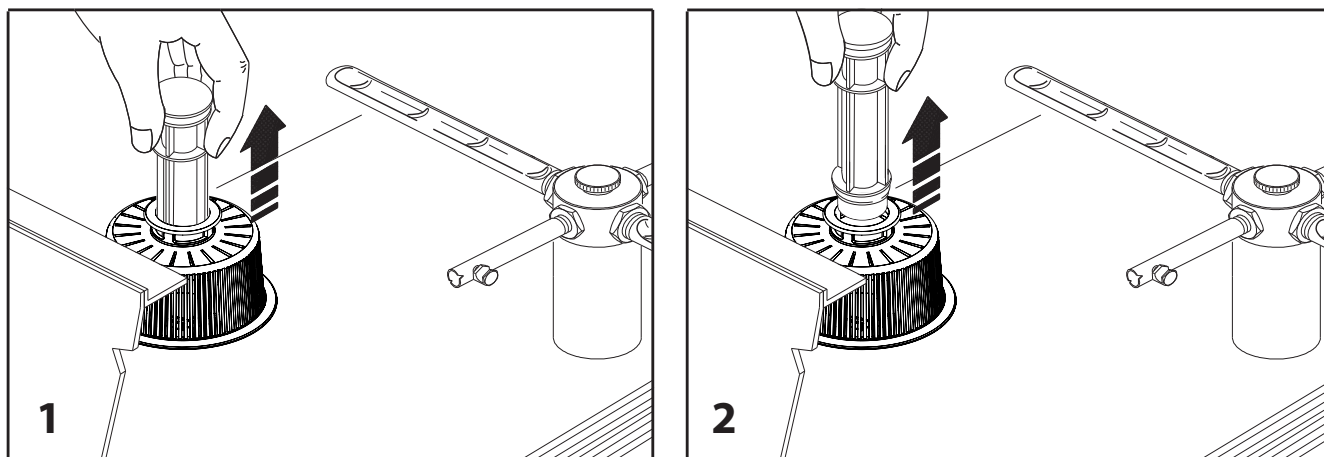

Fig. 16

Wait approximately five minutes to allow the heating elements to cool down before attempting to recover any fallen objects.

ATTENTION!



BURN HAZARD

4.4 Unladen test

Before starting the dishwasher, it is advisable to perform an unladen test to make sure that the machine was installed correctly.

4.5 Washing operations

A few basic rules must be observed to ensure correct hygiene for the items being cleaned:

- Remove any residual food from the dishes before washing them in the dishwasher (fig. 13)

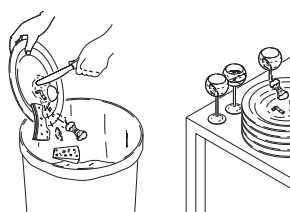
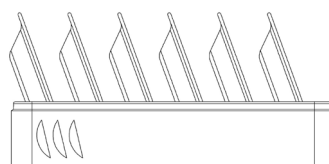

Fig. 13

- frequently replace the water in the tank according to the number of wash cycles that have been performed - at least 3 times a day
- dry the washed dishes with a clean cloth
- do not place the dishes on rubber cloths or on other water-retaining materials
- The washing pump filter must be kept clean and placed correctly (see chap.6 – PART TWO).
- The overflow must be positioned correctly

Pay attention to the correct positioning of the crockery in the 500x500 baskets: soup plates must be placed in the wide grid, while flat plates must be positioned in the narrow grid (refer to the indications printed on the basket). The basket allows the washing of 12 soup plates with a maximum diameter of 26 cm or 18 flat plates with a maximum diameter of 26cm.



Deep plates

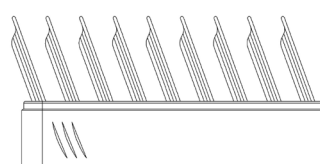

Flat plates

4.6 Electromechanical dishwasher operation

On fig. 14a, 14b, 14c you can see the control panel of the dishwasher and the reference to each control, according to the model of the dishwasher and the presence or absence of the drain pump.

FRONT LOADING DISHWASHER

CONTROLS	REF.
IGNITION SWITCH	1
CYCLE START BUTTON	2
MANUAL RINSE BUTTON	3
POWER LIGHT	4
WATER TEMPERATURE LIGHT	5
CYCLE INSERTED LIGHT	6

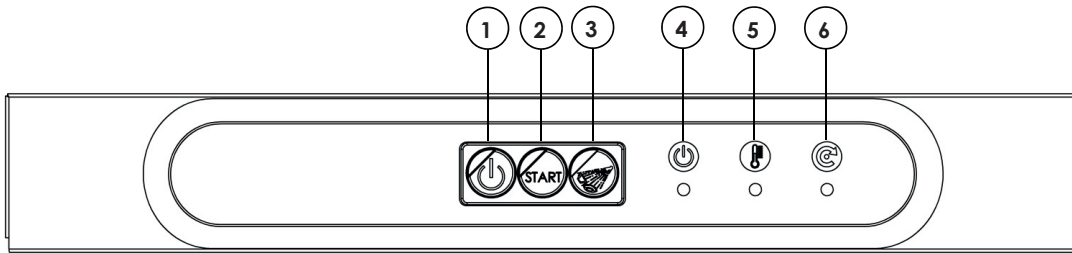

Fig. 14a

FRONT LOADING DISHWASHER WITH DRAIN PUMP

CONTROLS	REF.
IGNITION SWITCH	1
CYCLE START BUTTON	2
DRAIN PUMP BUTTON	3
POWER LIGHT	4
WATER TEMPERATURE LIGHT	5
CYCLE INSERTED LIGHT	6

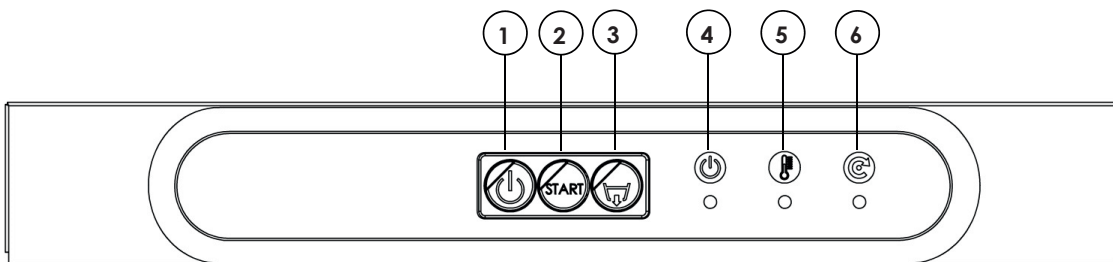

Fig. 14b

LID DISHWASHER

CONTROLS	REF.
POWER LIGHT	1
IGNITION SWITCH	2
DRAIN PUMP BUTTON	3
WATER TEMPERATURE LIGHT	4
CYCLE INSERTED LIGHT	5
WASHING TIMES SELECTOR	6

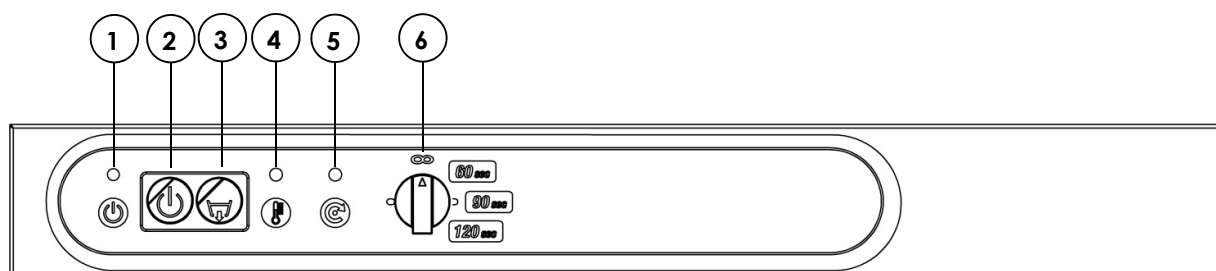

Fig. 14c

The following pages contain the instructions on the washing operations; some of them are automatically carried out by the dishwasher.

**ATTENTION**

**PAY ATTENTION WHEN THE OPENING AND CLOSING THE DOOR/LID OF THE DISHWASHER.
DO NOT USE THE DISHWASHER WHEN WEARING CLOTHING/ITEMS THAT COULD BECOME CAUGHT IN THE DISHWASHER COMPONENTS, LIMITING CAPACITY FOR NORMAL MOVEMENT.**

PHASE	DISHWASHER TYPE/REFERENCES FIGURE	
	Front loading dishwasher (ref. fig. 14a or 14b)	Dish washer with lid (ref. fig. 14c)
0. Initial checks	Check that the tank is completely empty and clean Check that the rotors are clean and free to turn Check that the filter is clean and reaches the bottom of the container. Check that the overflow tube is properly inserted in its housing	
1. Switch-on	Close the door of the dishwasher. Push the IGNITION SWITCH (1): the IGNITION SPY LIGHT (4) turns on	Close the lid of the dishwasher. Push the IGNITION SWITCH (2): the IGNITION SPY LIGHT (1) turns on
2. Water loading	The water is automatically loaded into the wash tank until it automatically reaches the top overflow pipe.	

PHASE	DISHWASHER TYPE/REFERENCES FIGURE	
3. Water heating	<p>The water is automatically heated. Before starting actual washing, wait for the time necessary for the water to heat up in the wash tank.</p> <p>During heating the WATER TEMPERATURE LIGHT (5) flashes. Upon reaching the pre-set water temperature, the WATER TEMPERATURE LIGHT (5) comes on.</p>	<p>Heating takes place automatically. Before starting actual washing, wait for the time necessary for the water to heat up in the wash tank.</p> <p>During heating the WATER TEMPERATURE LIGHT (4) flashes. Upon reaching the pre-set water temperature, the WATER TEMPERATURE LIGHT (4) comes on.</p>
4. Detergents and rinse additive dosage	<p>All dishwashers are equipped with automatic systems for the dosing of detergent and rinse aid; the settings are imposed by the installer at the time of installation.</p> <p>The detergent is dosed automatically during tank loading and during the rinse phase, while the rinse aid is dosed automatically during the washing phase.</p>	
5. Selecting the washing time	<p>The duration of the washing cycle is fixed and is 120sec. 105 sec. wash 15 sec. rinse Total 120 sec. cycle</p> <p>The times indicated may vary if the dishwasher has the drain pump installed, or if the technician has changed the rinsing time on the electronic board.</p>	<p>Before starting washing, select the desired washing time with the WASH TIME SELECTOR (6).</p> <p>Position 60sec: 45 sec. wash 15 sec. rinse Total 60 sec. cycle</p> <p>Position 90sec: 75 sec. wash 15 sec. rinse Total 90 sec. cycle</p> <p>Position 120sec: 105 sec. wash 15 sec. rinse Total 120 sec. cycle</p> <p>Position 240sec: 225 sec. wash 15 sec. rinse Total 240 sec. cycle</p> <p>The washing times indicated may vary if the dishwasher has the drain pump installed, or if the technician has changed the rinsing time on the electronic board.</p>

PHASE	DISHWASHER TYPE/REFERENCES FIGURE	
6. Washing	<p>Open the door, introduce the basket with the dishes (making sure the arrangement of the dishes respects the description contained in para. 3.4 – PART 2), close the door and press the CYCLE START KEY (2) to start the wash cycle: the CYCLE INSERTED LIGHT (6) comes on.</p> <p>The cycle ends when the CYCLE INSERTED LIGHT (6) turns off.</p>	<p>Raise the lid, insert the basket with dishes (making sure the arrangement of the dishes respects the description in para. 3.4 - SECOND PART), lower the lid and press the lid closure handle downwards: the CYCLE INSERTED LIGHT (5) comes on.</p> <p>downwards: the CYCLE INSERTED LIGHT (5) comes on.</p> <p>The washing/rinse cycle starts automatically.</p> <p>automatically.</p> <p>The cycle ends when the CYCLE INSERTED LIGHT (5) turns off.</p>
7. Supplementary rinse	<p><u>If the dishwasher is set up for manual rinsing activation (fig. 14a)</u> and to perform a further rinse, press the MANUAL RINSING BUTTON (3): an additional 5 sec. rinse will be performed.</p>	
8. Dishes unloading	<p>Open the door to remove the basket with the dishes.</p> <p>If the dishwasher is set up for manual rinsing activation (fig. 14a), to remove any misting from the dishes:</p> <ol style="list-style-type: none"> 1. insert the basket with the dishes back into the dishwasher 2. close the door 3. perform an additional rinse of 5sec. by pressing the MANUAL RINSING BUTTON (3) 	<p>Lift the lid to remove the basket with the dishes.</p>

4.7 End of service

Every day, after use:

1. turn off the dishwasher using the POWER SWITCH (1 figg. 14a, 14b or 2 fig. 14c)
2. remove the overflow pipe (fig. 16)
3. let the dishwasher drain completely,
if the dishwasher is equipped with a drain pump, operate it, keeping the DRAIN PUMP BUTTON pressed (3 Fig. 14b, 14c)
4. remove the electric power by turning off the main switch installed upstream of the dishwasher or disconnect it from the electric network
5. Remove and clean the wash pump filter (fig. 17) and any tank filters if present
6. carefully clean the wash tank
7. check and, if necessary, unscrew and clean the wash and rinse pipes
8. replace all the dishes removed, proceeding in reverse order
9. Leave the door/lid open for the time the machine is off.

4.8 Thermostop

The dishwasher is equipped with the function of serial thermostop which only ensures starting of the wash cycle if the water temperature has reached the set minimum (Tank Thermostop) and only enables rinsing if the boiler has reached the minimum temperature set (Boiler Thermostop).

At the end of the wash cycle before starting the rinse, the boiler temperature is checked: If the temperature is above the minimum value, the cycle continues correctly with rinsing. If the temperature is lower than the minimum value, the washing cycle is prolonged until reaching of the minimum temperature.

ATTENTION!



INJURY HAZARD



FALL HAZARD

WHEN THE DISHWASHER DOOR IS OPEN IT CAN BE AN OBSTACLE TO PERSONS AND TO OBJECTS NEAR THE MACHINE ITSELF.

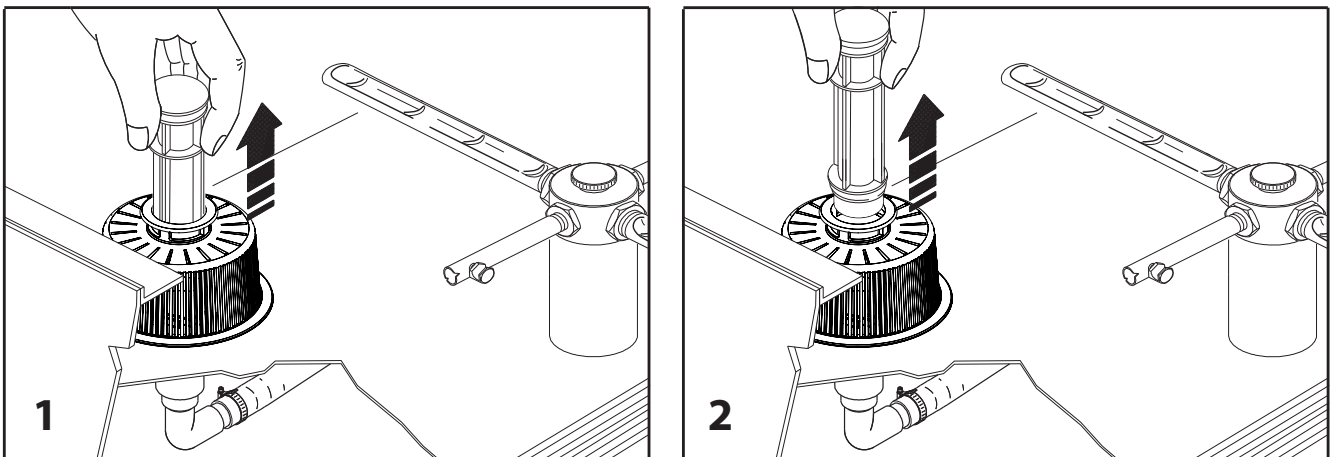

Fig. 16

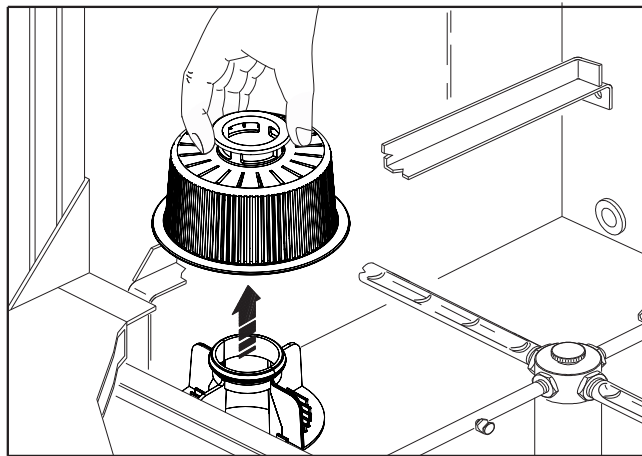

Fig. 17

5 Instructions for disassembly

ATTENTION!



INJURY HAZARD

DAMAGE HAZARD FOR THE DISHWASHER

Only skilled personnel should be allowed to disassemble the dishwasher.

The dishwasher should therefore be taken to the nearest authorised dealer to disassemble all or part of the dishwasher.

6 Maintenance

ATTENTION!



INJURY HAZARD



BURN HAZARD

MAINTENANCE MUST ONLY BE CARRIED OUT WHEN THE MACHINE IS SWITCHED OFF, DISCONNECTED FROM THE POWER SUPPLY NETWORK AND THE TANK IS EMPTY.

MOREOVER, MAINTENANCE SHOULD ONLY BE CARRIED OUT AFTER THE HEATING ELEMENTS HAVE COOLED DOWN (WAIT AT LEAST FIVE MINUTES).



THE ONLY EXCEPTION TO THIS RULE IS WHEN CHECKING THAT THE MICROSWITCH IS FUNCTIONING (SEE THE TABLE BELOW).

The table below shows a list of the necessary maintenance operations and their frequency. In case of technical problems, contact your Dealer.

6.1 Machine maintenance

Ordinary maintenance activities must be performed safely using protective gloves and goggles. Maintenance activities must only be carried out when the dishwasher is switched off and disconnected from the power supply and with an empty tank. Before performing maintenance, wait for the resistance cooling time (at least 5 minutes).

To clean the exterior walls of the dishwasher, use only a steel-specific neutral detergent and a soft, non-abrasive cloth. Attention: the degree of protection of the dishwasher is IPx1 therefore it is absolutely forbidden to use direct water jets to clean any component of the dishwasher. IT IS also prohibited to wash floors, walls or any other object installed near the dishwasher with a water jet or high-pressure cleaners. During normal maintenance and cleaning of the floor, avoid wetting the dishwasher plinth excessively. Avoid stagnating water near the dishwasher. For steel cleaning, do not use bleach or products containing chlorine or other substances that could corrode the steel. Do not use metal scourers, or other metal tools that could irreparably scratch the steel and other components of the dishwasher.

MAINTENANCE	FREQUENCY	NOTES
Wash tank cleaning	Daily	To be carried out with care.
Rotor cleaning	Daily	Dismantle the rotor by unscrewing the retaining nut and pulling it upwards (fig.18). Wash the rotor with water. Carry out the same operations for the upper rotor.
Wash pump filter cleaning	Daily	Remove the wash pump filter by pulling it upwards, then wash it and rinse it (fig. 19).
Cleaning of wash tank filters (if present)	Daily	Remove the wash tank filters by pulling them upwards then wash and rinse them.
Rotation control of the rotor	Daily	Check manually that the rotor rotates freely.
Outer surfaces cleaning	Every 1-2 days	Do not use solvents on the control panel.
Microswitch functioning check	Weekly	Check that the door microswitch works properly when the machine is on by opening/closing the door or by lifting/lowering the lid.
Power supply cable and water hose check	Every 6 months	<p style="text-align: center;">ATTENTION!</p> <p> ELECTROCUTION HAZARD</p> <p> INJURY HAZARD</p> <p><u>In case these parts are damaged, disconnect the dishwasher from the power supply without touching the electric cable</u> (turn the switch upstream of the dishwasher to the "off" position or disconnect the entire power supply network to which the dishwasher is connected). <i>Immediately contact your Dealer and have the machine repaired by qualified personnel.</i></p> <p><u>Do not use the dishwasher until it has been repaired.</u></p>

Periodic technical maintenance is also required by a specialist technician who must issue the verification report:

MAINTENANCE	FREQUENCY	NOTES
General visual inspection by the technician who installed the dishwasher	At the time of installation	The technician must issue a report confirming correct operation of the dishwasher. The report must include the date of the intervention, the signature of the technician and the signature of the customer/maintenance manager of the premises.
A general visual inspection by the technician who installed the dishwasher. Check the general condition of the internal components, the functionality of the dispensers and make sure that there are no liquid leaks from the dispensers or water leaks from the hydraulic circuit, including the pumps. Check the condition of the water inlet and drain hose connections	After 6 months from the first installation	

MAINTENANCE	FREQUENCY	NOTES
<p>Check the functionality and wear of all components, replacing any if necessary</p> <p>Check boiler cleanliness (empty it and check for limescale)</p> <p>Check boiler heating element seal</p> <p>Check for leaks from the wash pump</p> <p>Verification of the integrity of the hydraulic circuit</p> <p>Verification of the integrity of the load tube</p> <p>Verification of the integrity of the drain pipe</p> <p>Check the status of the water inlet and drain hose connections</p> <p>Checking the tightness of the clamps</p> <p>Check the integrity of the electrical wiring (replace any wires damaged by external/environmental causes)</p> <p>Verification of the integrity of the temperature probes and of the correct temperature detected</p> <p>Verification of all electrical connections (faston, terminal block, electrical resistance terminals)</p> <p>Check that all the wires are correctly tightened in the contactor terminals, if present (three-phase models)</p> <p>Check the electric cable, plug and/or connections to the panel</p> <p>Verification of the integrity and cleanliness of the air trap</p> <p>Check that the pressure switch is working properly</p> <p>Check that the solenoid valve is working properly</p> <p>Cleanliness of the solenoid valve filter</p> <p>Replacement of the detergent and rinse aid dispenser tubes even if the machine has only worked partially for 12 months.</p> <p>Replacement of the carbographeite bushings of the impellers to always guarantee correct rinsing</p>	Every 12 months	<p>The technician during the phases of verification and/or replacement of the components (which must take place with original spare parts), should they detect further anomalies, will need to make the necessary repairs.</p> <p>If it is impossible to perform the repair immediately, the dishwasher must remain unused and an "out of order" sign must be affixed.</p> <p>Upon completion of the checks/repairs, the technician will issue the report confirming correct operation of the dishwasher.</p> <p>The report must include the date of the intervention, the signature of the technician and the signature of the customer/maintenance manager of the premises.</p>
<p>Carry out all the necessary checks every 12 months and also:</p> <p>The following components must be replaced with original spare parts:</p> <p>Washing pump gaskets</p> <p>Water inlet hose</p> <p>Water drain hose</p> <p>Seal in the boiler heating element</p> <p>Tank pressure switch (and boiler if present)</p> <p>Solenoid valves</p>	Every 24 months	Follow the instructions in the 12-month notes

Non-compliance with the above checks and the technician's failure to issue the reports will invalidate the product warranty. The Manufacturer is not liable for malfunctions and/or damage caused by negligence and failure to observe the periodic maintenance rules indicated in this use and maintenance manual.

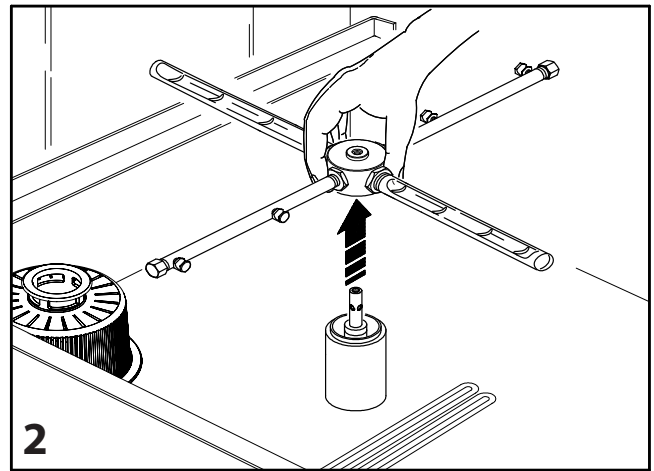
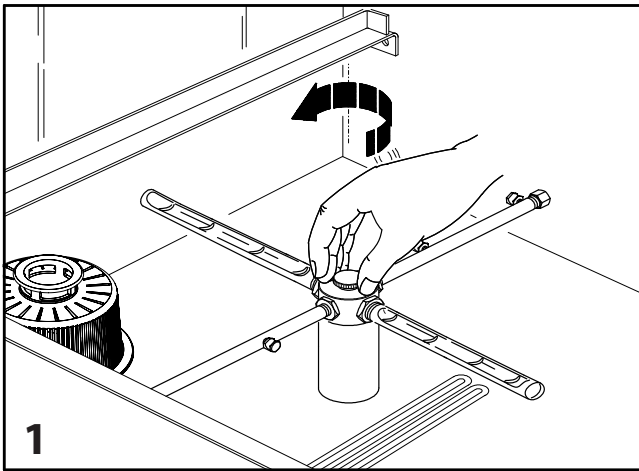

Fig. 18

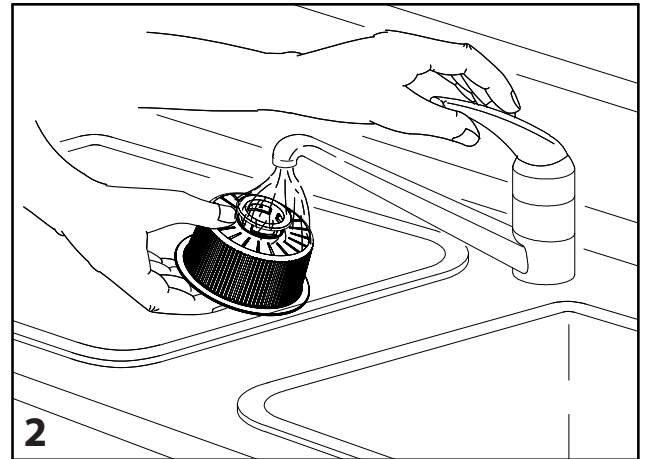
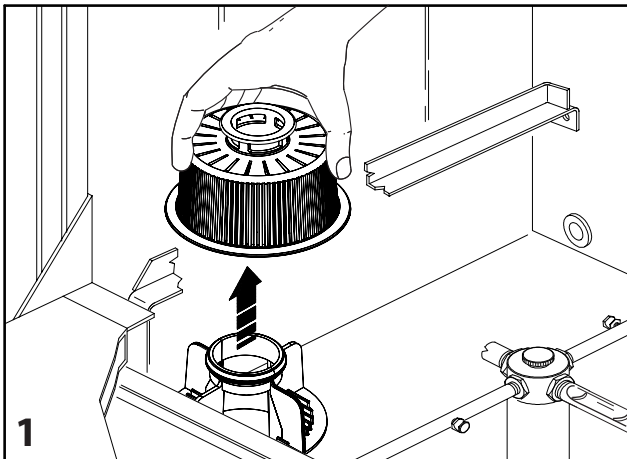
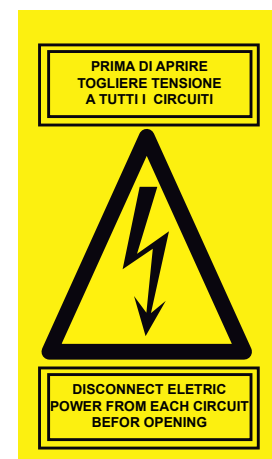

Fig. 19

7 Residual hazards

The alternating current mains power supply represents a source of residual hazard.

Warnings placed in convenient positions on the dishwasher warn operators of these hazards, in compliance with the Safety Standards, as shown here to the side.



8 Instructions for emergency situations



ATTENTION

Emergency situations that are likely to arise during use of the dishwasher are:

- *loss of insulation*
- *electric shock*

In all situations in which the dishwasher is not working, or not working properly, thus generating possible hazardous circumstances, the electric power supply must be immediately disconnected by switching off the switch upstream and by disconnecting the mains power cord.

In the event of electrocution or electric shock, carefully follow the precautions set out by the Safety Regulations. Do not touch the injured person directly, but switch off the switch upstream.

In all situations in which the dishwasher is not working, or not working properly, thus causing the hazardous situations described above, or after one of these situations has occurred, do not use the dishwasher and have it checked and repaired by qualified personnel.

9 Troubleshooting

Before leaving the factory, each machine is thoroughly tested by specialist engineers to make sure that it works perfectly.

However, in the event of a fault, before calling for service, the following trouble shooting operations may be attempted.

PROBLEM	POSSIBLE CAUSE	SOLUTION
0. The dishwasher does not turn on	THE POWER SWITCH (fig. 14a or 14b or 14c, depending on the model) is in the "off" position	Turn the IGNITION SWITCH (fig. 14a or 14b or 14c, according to the model) to the ON position.
	The switch upstream of the dishwasher is in the OFF position.	Turn the switch upstream of the dishwasher into the "on" position
	The plug or the power cable are damaged. ATTENTION!  ELECTROCUTION HAZARD	<u>In case these parts are damaged, disconnect the dishwasher from the power supply without touching the electric cable</u> (turn the switch upstream of the dishwasher to the "off" position or disconnect the entire power supply network to which the dishwasher is connected). <i>Immediately contact your Dealer and have the machine repaired by qualified personnel.</i> <u>Do not use the dishwasher until it has been repaired.</u>
1. The dishwasher does not fill with water	There is no electricity.	Wait for electricity to come back. to come back.
	Dishwasher door/lid not closed	Open the supply valve for water
	Power valve filter for water clogged	Clean the power valve filter for water
	Supply valve closed	Open the supply valve
	Filling up of water softener upstream	Wait until filling up is completed

PROBLEM	POSSIBLE CAUSE	SOLUTION
2. Even if you press the STARTING CYCLE SWITCH the cycle does not start	Dishwasher door/lid not closed	Close the door/lid of the dishwasher
	The switch upstream of the dishwasher is in the OFF position.	Turn the switch upstream of the dishwasher into the "on" position
	The STARTING CYCLE SWITCH was not pressed for at least 2 seconds	Press the STARTING CYCLE SWITCH for at least 2 seconds again
3. The wash cycle is noisy	The wash pump filter (fig. 19) is clogged.	Wash and rinse the wash pump filter (fig. 19);
	The washing arms of the rotor (fig. 18) knock the parts to be washed protruding from the basket	Position the dishes so that they cannot be struck by the washing arms of the rotor by following the instructions in para. 3.4 – PART TWO
4. Inadequate rinsing	The water supply pressure is less than 1.5 bar	Contact an installer to install a supplementary pump to increase the Supply
	Power valve filter for water is clogged	Clean and rinse the water supply valve filter.
	The nozzles of the rotor are blocked.	Wash and rinse the nozzles of the rotor.
	The rotor arms do not turn freely	- Position the dishes so that they are not struck by the washing arms of the rotor, following the instructions in para. 3.4 – PART TWO - Wash and rinse the rotor.
5. The wash produces excessive foam.	The dishwasher has not finished the phase of heating of the water in the tank	Before starting actual washing, wait for the time necessary for the water to heat up in the wash tank. Upon reaching of the pre-set water temperature, the WATER TEMPERATURE LIGHT comes on
	Excessive rinse aid has caused this foaming	Contact the installer to reduce the amount of rinse aid.
	Soaking of the dishes with unsuitable detergent	Avoid soaking with foaming detergents
6. The rotor does not turn freely	The washing arms of the rotor (fig. 18) knock the parts to be washed protruding from the basket	Place the dishes so that they do not become hit by the washing arms of the rotor by following the instructions in para. 3.4 – PART TWO
	The rotor needs cleaning	Wash and rinse the rotor
7. The dishwasher does not drain the water	The drain pipe (fig. 21) is blocked or compressed	Remove the blockage from the drain pipe
	The drain pump filter (if supplied – fig. 21) is clogged	Wash and rinse the drain pipe filter.
	The pump does not drain properly	Contact the installer to reduce the replacement of the drain pump

PROBLEM	POSSIBLE CAUSE	SOLUTION
8. The wash result is unsatisfactory	The dishwasher has not finished the phase of heating of the water in the tank	Before starting actual washing, wait for the water heating time in the wash tank. When the pre-set water temperature is reached, the WATER TEMPERATURE LIGHT comes on
	Water in the tank is excessively dirty	Change the water
	The washing arms of the rotor (fig. 18) knock the parts to be washed protruding from the basket	Place the dishes so that they do not become hit by the washing arms of the rotor by following the instructions in para. 3.4 – PART TWO
	The rotor needs cleaning	Wash and rinse the rotor
	The nozzles of the rotor are blocked.	Wash and rinse the nozzles of the rotor.
	No detergent	Contact the installer to increase the amount of rinse aid.
9. The water tank is full of limestone	Excessive hardness of the inlet water	Contact the installer to install a softener upstream
		Perform descaling of the tank with specific products for industrial dishwashers. Follow the instructions provided by the manufacturer of the descaling agent. <div style="text-align: center;">  <p>ATTENTION! WARNING RISK OF BURNS FROM ACID</p> </div>

PROBLEM	POSSIBLE CAUSE	SOLUTION
10. Presence of brown spots or grease in the tank after emptying	The tank is stained with coffee or grease	Increase daily water refills and contact the installer to increase the amount of detergent.
11. Spots of rust in the wash tank	Use of detergent with high content of chlorine	Change the type of detergent according to the instructions given in paragraph 11. Remove rust with specific products without scratching the surface of the steel
	Using bleach in the tank	Never use bleach. Remove rust with specific products without scratching the surface of the steel
	Introduction into the tank of crockery previously cleaned with iron scourers	Never use scouring pads or wire brushes in the manual pre-wash. Remove rust with specific products without scratching the surface of the steel
	Washing of dishes or iron items	Do not wash iron items

If the problem persists even after you have followed these instructions, please contact the nearest officially appointed Service Station, reporting model data (fig. 5) and type of failure.

9.1 Electromechanical dishwasher alarms

In the event of anomalies, the dishwasher stops working and signals the problem with flashing of the 2 "WATER TEMPERATURE LIGHTS" (ST) and/or "CYCLE INSERTED LIGHT" (SC) (see paragraph 4.6).

All warnings persist until the dishwasher is switched off and until subsequent switching on.

Some serious alarms send the machine into "safe" mode (total block).

If after having performed the appropriate checks and having switched the machine off and back on the alarm appears again, contact our technical service.

The type of flashing describes the type of fault that has occurred as explained below:

ALARM CODE	ALARM DESCRIPTION	CHECKS PERFORMED BY THE END USER
The SC light flashes The ST light removes off	Boiler probe fault: the boiler temperature probe is faulty. Boiler heating is disabled	Request the intervention of a technician
The ST light flashes The SC light remains off	Tank probe fault: the tank temperature probe is faulty. Tank heating is disabled	Request the intervention of a technician
The 2 ST and SC lights flash simultaneously	Tank loading timeout: the tank has not been loaded within the maximum time permitted	Water mains valve does not supply water Overflow tube not inserted or inserted incorrectly Rinse jets clogged Water supply hose blocked Upstream water softener not working
The ST and SC lights flash quickly alternately	Drain timeout: the tank pressure switch was not open at the end of the manual drain cycle	Make sure that the overflow has been removed from its seat and start an additional drain cycle. If the alarm persists, request technical assistance. CAUTION RISK OF HOT WATER
The ST and SC lights flash slowly alternately	Heating timeout: the dishwasher has not heated the water in the maximum time permitted. Heating is disabled	Overflow tube inserted incorrectly. If the problem persists, request technical assistance

10 Personnel training

The personnel must be trained regarding the operations for loading, unloading and preparation for use of the machine.

All these operations are relatively simple and require normal prudence in order to avoid injuries and accidents.

11 Useful tips

Here are some useful tips to complete dishwasher operation:

- *Check the level of rinse aid and detergent in the outer container, and replace if necessary (fig. 22)*
- *The washing and rinsing arms must be clean and equipped with jets and taps*
- *Use only industrial and low-foam detergents*
- *Use only liquid industrial detergent and rinse aid products similar to those supplied by us or with an equivalent composition suitable for dosing using the dosing pumps already installed inside the dishwasher.*
- *Use the doses recommended by the detergent manual (para. 4.6 – PART II) or by the manufacturer of the detergent itself*
- *Do not fill the detergent and rinse aid containers with new product to prevent crystallisation of the product which, aspirated by the dispensers, damages the tubes*
- *Upon each tank change clean the tubes. In this regard, before inserting the tubes into the new tanks, place the suction tubes into a basin filled with warm water and perform 2 cycles of vacuum*

cleaning.

- The detergent and rinse aid tubes must be replaced at least 1 time per year or as soon as the maintenance request message appears (only for electronic dishwashers)
- Make sure that the detergent and rinse aid intake filters are always installed in the respective tubes and thoroughly clean. Replace them if they are excessively dirty and clogged with crystallised detergent.

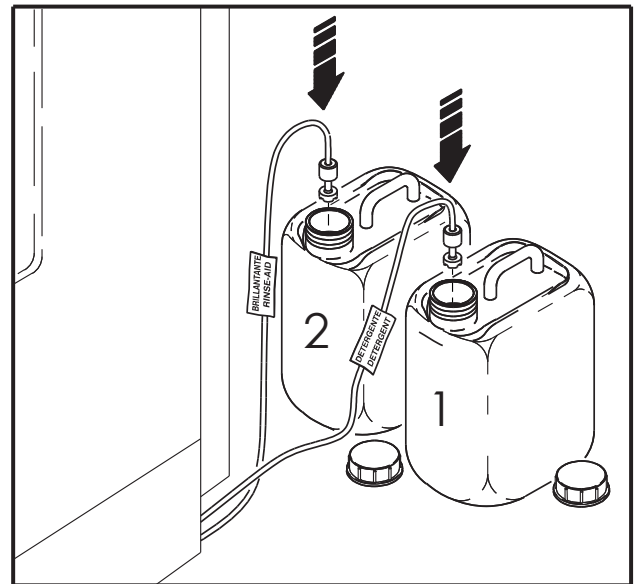

Fig. 22

12 Instructions for disposal

Instructions for the disposal of electrical devices.

The label shown to the right is applied to electrical devices you have bought and means that the appliance cannot be disposed of as common waste but must be disposed of separately.

In fact, waste deriving from electrical or electronic devices must undergo special treatment in order to prevent the pollutants contained in the devices from being dispersed and to protect the environment and human health. Moreover, it will be possible to reuse/recycle part of the material of which this waste is made up, thus reducing the depletion of natural resources and the quantity of waste to be recycled.

WARNING

DUE TO ITS POLICY OF CONTINUOUS PRODUCT IMPROVEMENT, THE MANUFACTURER RESERVES THE RIGHT TO MAKE ANY CHANGES DEEMED NECESSARY.

THE MANUFACTURER CANNOT BE HELD RESPONSIBLE IF THE INSTRUCTIONS CONTAINED IN THIS MANUAL ARE NOT OBSERVED.



Stick on the serial number label